



EGX-400/600 ADA Hardware and Software Setup Guide v1.0



EGX-400/600 ADA Hardware and Software Setup Guide

- ❖ This guide covers configuration of the Raster™ Braille Dot cutter and Character cutter.
- ❖ Raster™ Pen Attachment.
- ❖ FlexiEngrave and EngraveLab software configuration and workflow.

NOTES:



Configuration of the Raster™ Braille Dot Cutter and Character Cutter



Configuring Engraving Cutters

- ❖ Switch the primary power on which is located on the left rear of the unit.
- ❖ Turn the Emergency (secondary power) switch clockwise to power the unit on.
- ❖ The control panel will power on and display the model and boot version. Once completed the display will read "HIT ENTER KEY".
- ❖ Press the ENTER key to initialize the unit.
- ❖ Once the initialization is completed, the carriage will be located to the View position (Left rear).
- ❖ Place the adhesive sheet (AS-10) in the lower left corner of the table and place the material.

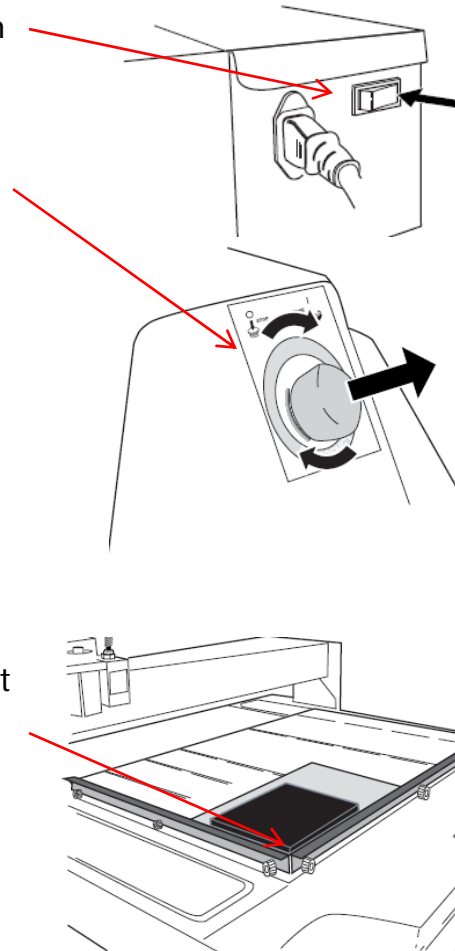

NOTES:

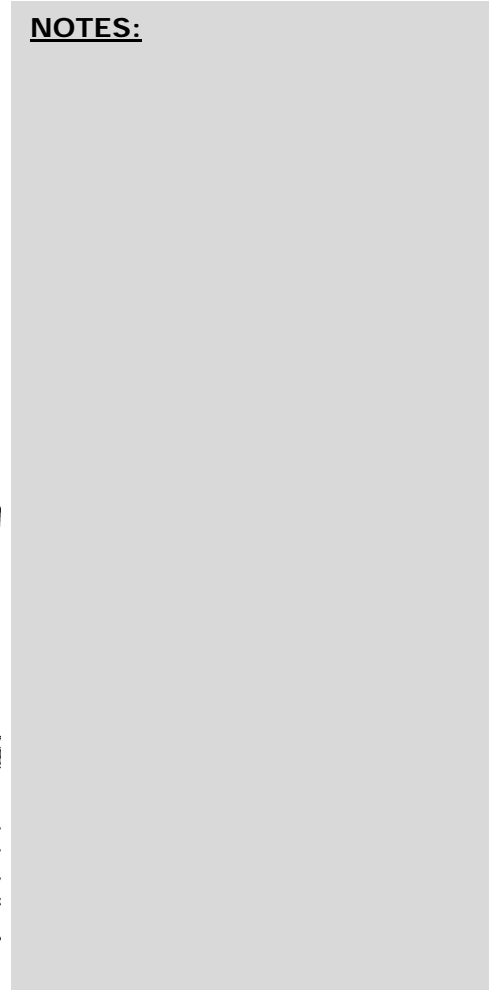



Configuring Engraving Cutters

- ❖ On the control panel press the MENU key multiple times until the I/O, OTHERS, TEACHING, SELF menu is displayed.
- ❖ Using the arrow keys on the control panel move the cursor to OTHERS and press the ENTER key to enter the sub-menu.
- ❖ Press the MENU key multiple times until AUTO Z CONTROL is displayed.
- ❖ Using the arrow keys on the control panel move the cursor to ON and press the ENTER key to set the value (shown with brackets).
- ❖ Press the MENU key until you return to the main screen.

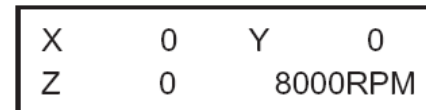

NOTES:



Configuring Engraving Cutters

- ❖ Using the arrow keys on the control panel move the carriage so that the spindle unit is over the lower left corner of the material.
- ❖ Once the spindle is over the lower left corner of the material, press the XY ORIGIN SET button and press the ENTER key to set that as your origin point.
- ❖ Remove the cutter tool from the cutter knob (brass knob) and install the cutter knob on the top of the spindle assembly.
- ❖ Install the solid collet to the bottom of the spindle assembly and tighten it with the supplied spanner wrenches 17mm on the bottom of spindle and 10mm on the collet.
 - **NOTE:** Do not use the spanner wrench on the Top Spindle Nut as you will damage the bearings if you loosen or tighten it.

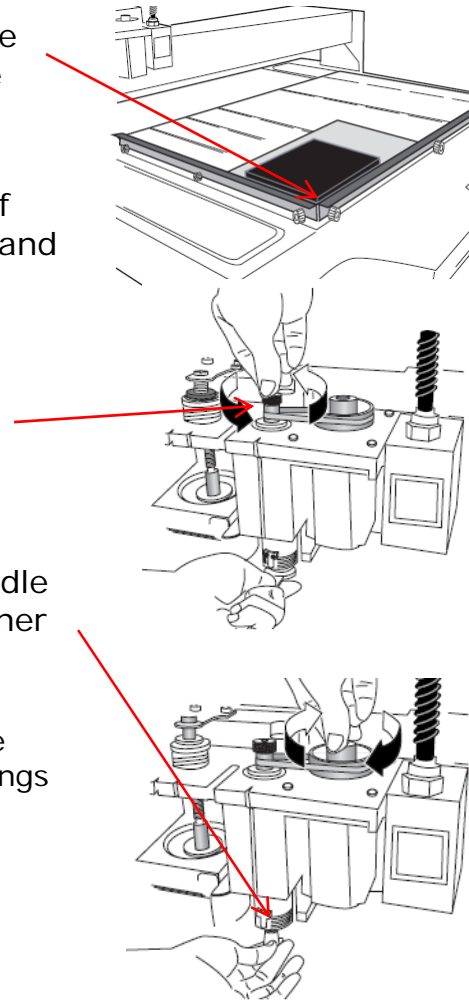

NOTES:



Configuring Engraving Cutters

- ❖ Install the Nosecone assembly on the spindle assembly counterclockwise until it stops and then clockwise 2 full turns and set to 0 (may need to mark the nosecone to indicate the 0 position).
 - **NOTE:** Be careful not to cross thread the nosecone to the spindle threads. Doing so will damage the spindle unit.
- ❖ Turn the nosecone clockwise an additional 42 clicks (each tick mark is equal to 0.001") . This will adjust the tool for 0.042" which is the depth for the Raster™ Braille.
- ❖ Loosen the Z screw lock nut. This will allow the Z Axis to "float".
- ❖ Using the arrow keys move the nosecone over a flat area of the material.

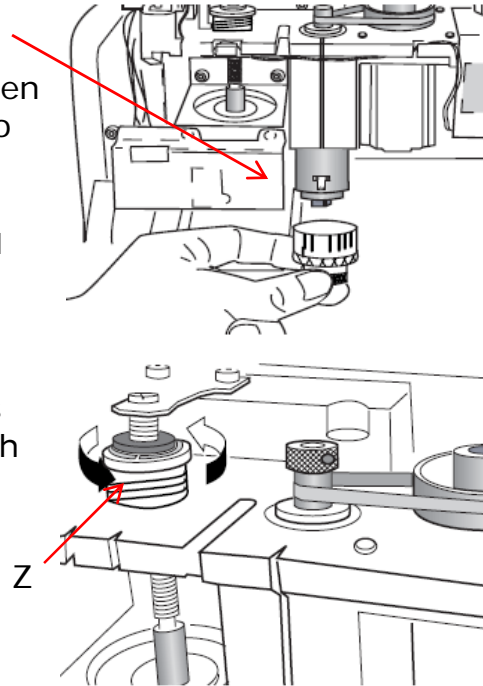

NOTES:



Configuring Engraving Cutters

- ❖ Place a flat plate under the nosecone and insert the cutter until it touches the plate.
- ❖ Tighten the cutter to the brass knob. This will zero the cutter for the proper cut depth for the Raster™ Braille.
- ❖ Remove the brass cutter knob and cutter from the spindle as one piece. Do not loosen the cutter from the brass knob.
- ❖ Rotate the nosecone counter clockwise 9 clicks which will adjust the depth to 0.033" for the pictogram / raised text cutter.
- ❖ Insert the character cutter and brass knob onto the spindle and again place a flat plate under the nosecone and insert the cutter until it touches the plate.
- ❖ Tighten the cutter to the brass knob. This will zero the cutter for the proper cut depth for cutting the pictograms and raised text.

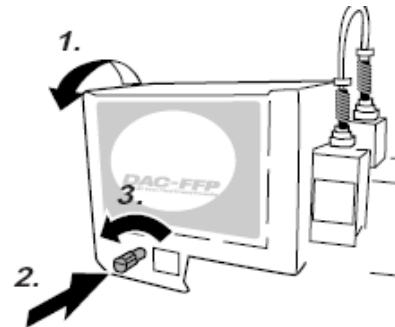
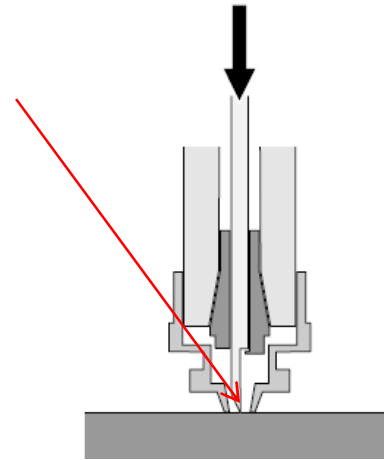

NOTES:



Configuring Engraving Cutters

- ❖ Turn the nose cone counterclockwise back to the originating zero position (35 clicks).
- ❖ Both cutters are configured for the proper depth and only need to be removed with the brass knob to switch between the two.

NOTES:



Configuring The Raster™ Pen Attachment from Accent Signage Systems, Inc.



Configuring Raster™ Pen Attachment

- ❖ Using the Z+ key on the Control Panel, raise the Z Axis its maximum clearance.
- ❖ Ensure that the cutout on the Raster™ Pen mounting block is on the right.
- ❖ Align the index pins on the Raster™ Pen with the opening located down the center of the spindle unit housing and ensure that the top of the Raster™ Pen block is flush with the spindle housing.
- ❖ While rotating the mounting block counter clockwise, tighten the set screws to attach the Raster™ Pen attachment to the spindle housing. Tighten the screws in an alternating fashion.

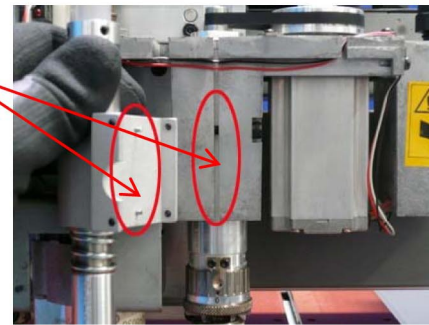
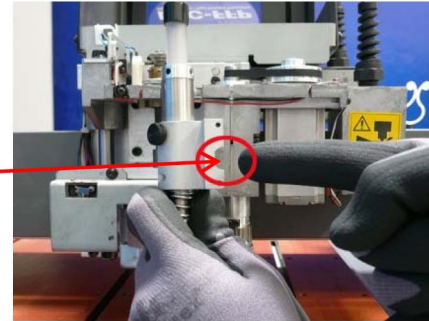

NOTES:

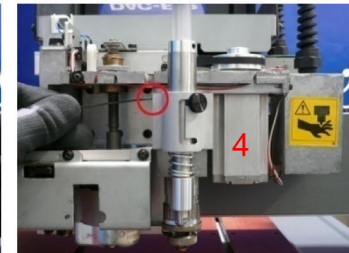
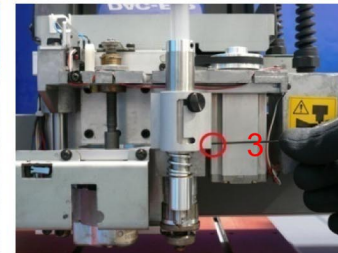
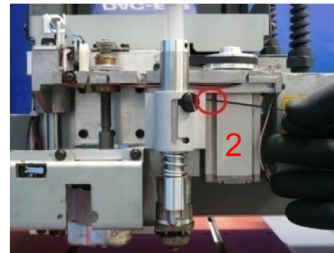
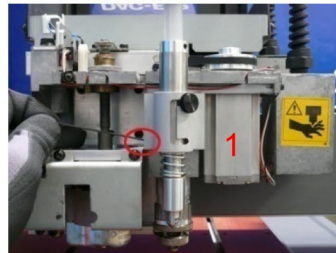
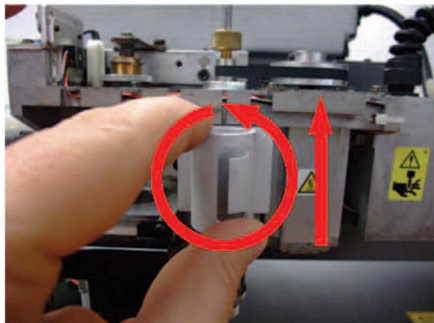



Configuring Raster™ Pen Attachment

- ❖ Remove the 2 screws that hold the cover latch plate to the housing.
- ❖ Remove the lower cable tie that holds the wiring harness to the carriage housing.
- ❖ Rotate cable tie mount 180 degrees and install new cable tie.

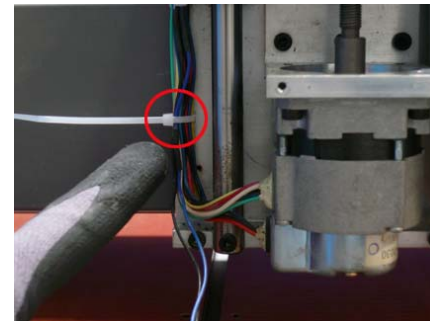
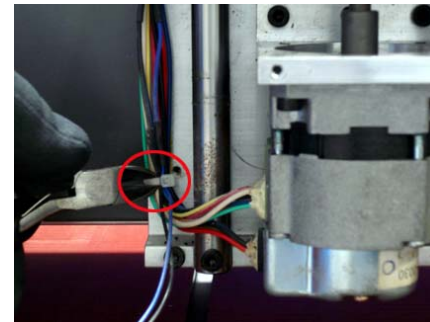
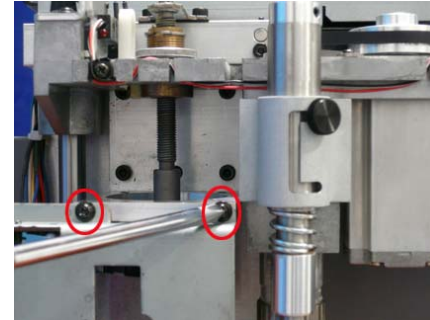

NOTES:



Configuring Raster™ Pen Attachment

- ❖ Install provided acrylic spacer between the latch plate and the motor .
- ❖ Insert provided screws to reattach the latch plate.
- ❖ Close the spindle cover and your Raster™ Pen is now ready for operation.
- ❖ Figure A shows the Raster™ Pen in the up position.
- ❖ Figure B shows the Raster™ Pen in the down position for Raster™ insertion.
- ❖ Fig. C shows the Z Axis screw in the locked position.

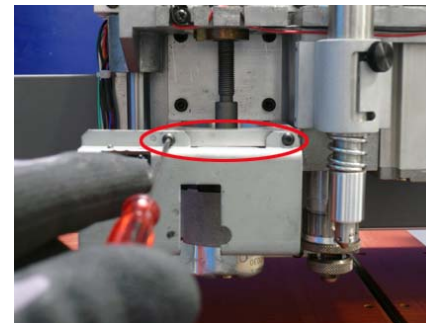

NOTES:

Fig. A

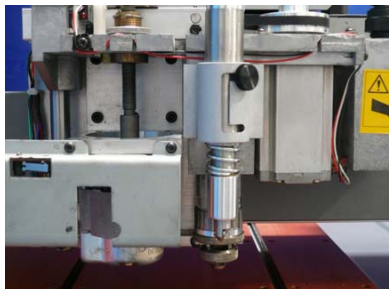

Fig. B

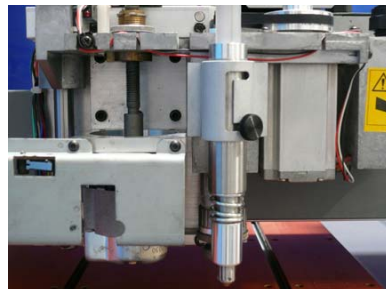
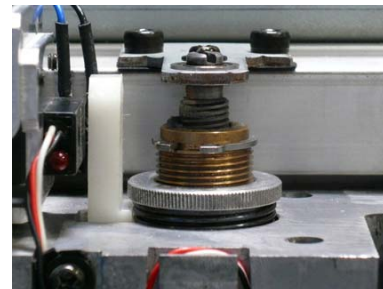

Fig. C





Setting and using the Raster™ Pen Attachment

- ❖ To use the Raster™ Pen attachment, tighten the Z Axis screw.
- ❖ Press the MENU key multiple times until the I/O, OTHERS, TEACHING, SELF menu is displayed.
- ❖ Select the OTHER menu and press the ENTER key.
- ❖ Press the MENU key multiple times until the AUTO Z Control Menu is displayed and press the ENTER key.
- ❖ Select AUTO Z CONTROL OFF and press the ENTER key.
- ❖ Press the MENU key multiple times to get back to the default screen.
- ❖ Press the Z- key to lower the Raster™ Pen to the surface of the material so the spring compresses slightly and set this as the Z0 Origin.
- ❖ Resend Braille job with proper offset to insert the Raster™ beads in place.

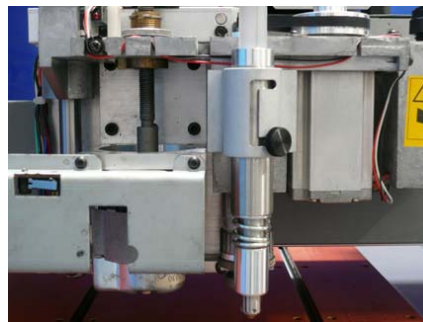
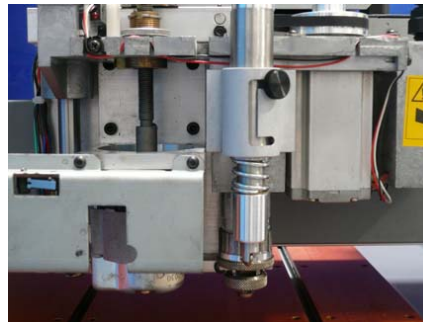
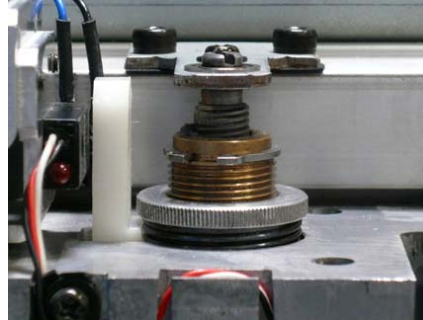

NOTES:



Flexi8
ENGRAVE



Configuring Software for Raster™
Braille, Character cutter and Raster™
Pen with EngraveLab / FlexiEngrave



EngraveLab Configuration for ADA/Braille Signage.

- ❖ Launch EngraveLab.
- ❖ Setup Braille job in accordance with ADA Laws, guidelines and regulations. Please refer to software documentation for generating Braille data.
- ❖ Click on Engrave and Engraving Defaults to configure the driver for the Braille drill.
- ❖ Select the driver, set tool for Braille, uncheck Output Tool Paths and click Apply.
- ❖ Click on Tool options and set Cut Velocity to 3.9"/sec., Plunge Velocity to 0.3937"/sec. and Clearance Height to .125" and click OK.
- ❖ Click Close on the Output window.
- ❖ Install Braille cutter and configure engraver for the Braille drill.
- ❖ Select the Braille component and click Engrave, Output and click on the Engrave icon to output the Raster™ Braille.

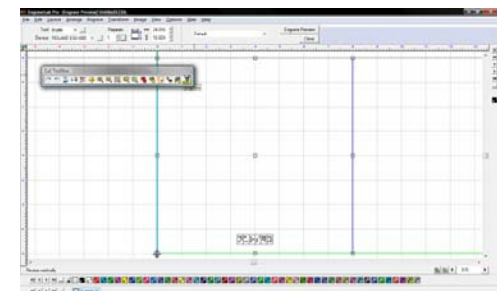
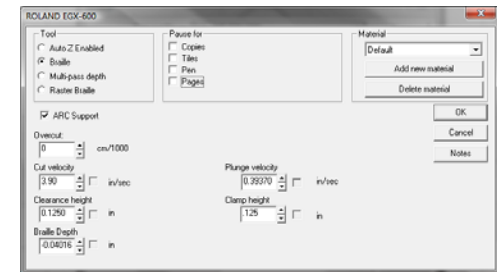
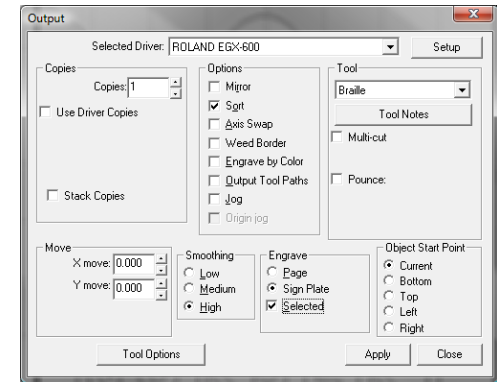



EngraveLab Configuration for ADA/Braille Signage.

- ❖ Once the Braille is output, configure the engraver for the Raster™ Pen Attachment.
- ❖ Click on Engrave and Engraving Defaults.
- ❖ With EngraveLab v8.0 under the tool option, select Raster™ Braille. With EngraveLab 7.1 under the tool option, select Multi Pass Depth.
- ❖ Input the Y offset value which is measured from the center position of the Raster™ Pen to the center position of the tool in the spindle unit. The default value to start with is 1.49". This value can be adjusted to fine tune the placement of the Raster™.
- ❖ Once the value is set, click on Apply to set the value. Make note of this value.
- ❖ Click on Tool Options and set the Cut Velocity to 3.9"/sec., Plunge Velocity at 1.9"/sec. and Clearance Height to 0.25" and click OK.
- ❖ Click Close, Select the Braille and click on Engrave, Output and click on the Engrave icon to output the Raster™ Braille insertion.
- ❖ The engraver will no insert the Raster™ Braille using the pen attachment.

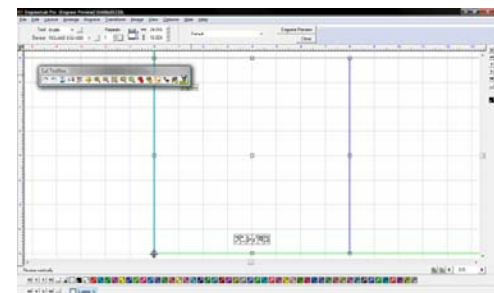
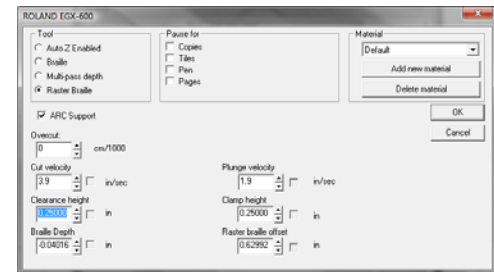
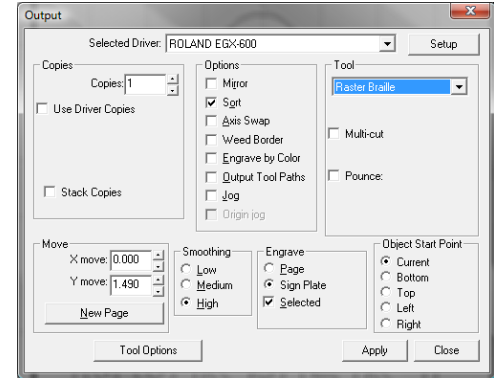



EngraveLab Configuration for ADA/Braille Signage.

- ❖ Apply the tactile material in the area where the pictogram/text is located.
- ❖ Configure the engraver for cutting out the pictogram and text and insert the character cutter.
- ❖ Click on Engrave and Engraving Defaults and for the Tool select Auto Z Enabled, click on Output Tool Paths and ensure that the Also Cut Contour Paths box is unchecked and click OK.
- ❖ Set the Y Move to 0.000.
- ❖ Click on Tool Options and set the Cut Velocity to 1.0"/sec. and Plunge Velocity to 1.9"/sec. and click OK and Close.
- ❖ Select the pictogram and text and output to the engraver to route out the tactile material.
- ❖ Brush off the excess material and weed away the tactile material to show the finished product and frame and/or mount.
- ❖ Your ADA compliant sign is now complete.

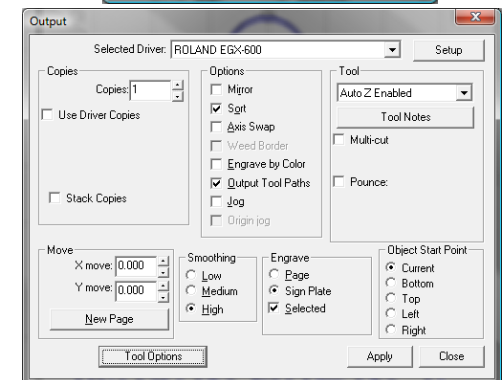
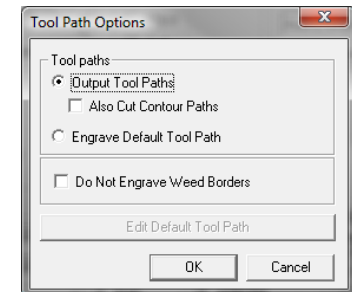
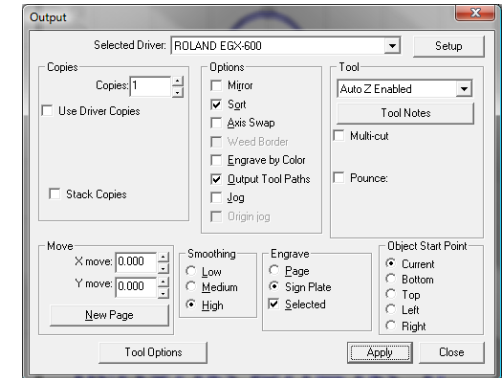



FlexiEngrave Configuration for ADA/Braille Signage.

- ❖ Launch FlexiEngrave.
- ❖ Setup Braille job and appropriate toolpaths in accordance with ADA Laws, guidelines and regulations. Please refer to software documentation for generating Braille data.
- ❖ Select the entire graphic (pictogram, text and Braille) and click on the Engrave icon. This will launch the Production Manager.
- ❖ Setup and configure the engraver driver. Refer to the SAI documentation for details.
- ❖ In the General tab select the Braille toolpath and ensure that the Material size matches what is installed on the engraver.
- ❖ Select the Panel tab and ensure that Panel to Border is selected.

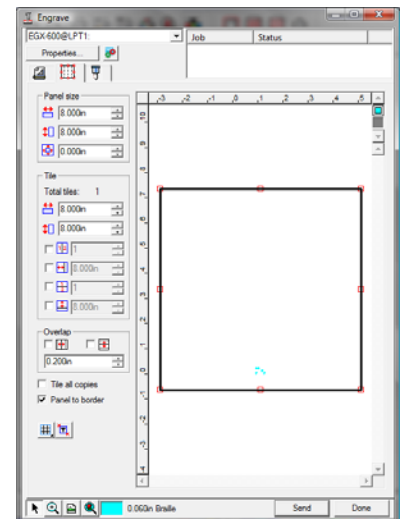
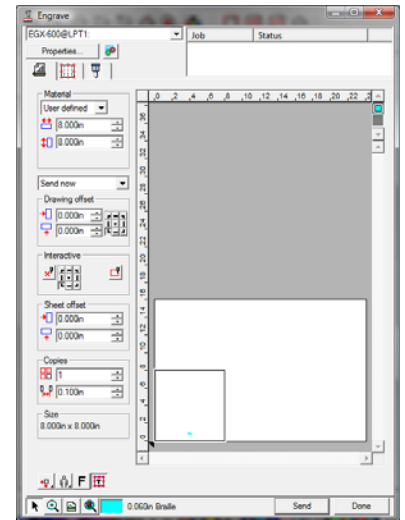



FlexiEngrave Configuration for ADA/Braille Signage.

- ❖ Click on the options tab and double click the 0.060in. Braille tool.
- ❖ Set the XY Velocity to 100mm/sec., Z Velocity to 2mm/sec. And Spindle RPM to 14000RPM and click Apply.
- ❖ Configure the engraver and the Raster™ Braille drill tool and select Send to output the Raster™ Braille to the engraver.
- ❖ Once Braille drill has been engraved, lower the Raster™ Pen attachment for inserting the Raster™ beads.

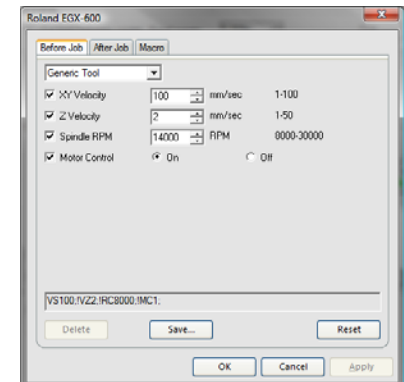
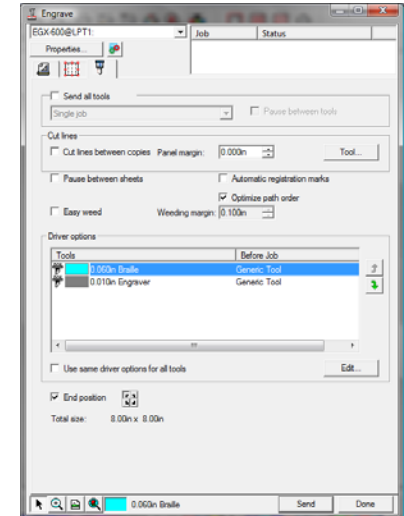



FlexiEngrave Configuration for ADA/Braille Signage.

- ❖ Click on the General tab and input the Y offset value which is measured from the center position of the Raster™ Pen to the center position of the tool in the spindle unit. This value is set under the Drawing Offset section. The default value to start with is 1.49" and can be adjusted to fine tune the placement of the Raster™.
- ❖ Click Send to output the Braille job to the engraver with the supplied offset value. The Raster™ Pen attachment will insert the Raster™ beads.
- ❖ Apply the tactile material in the area where the pictogram/text is located.
- ❖ Select the Pictogram and text toolpath and configure the engraver for cutting out the pictogram and text and insert the character cutter. Ensure that the Drawing Offset for the Y is set to 0.000in.
- ❖ Click on the Options tab and double click the 0.010in Engraver toolpath.
- ❖ Set the XY Velocity to 25mm/sec., Z Velocity to 50mm/sec. and spindle speed to 24000RPM and click OK and click Send to output the file.

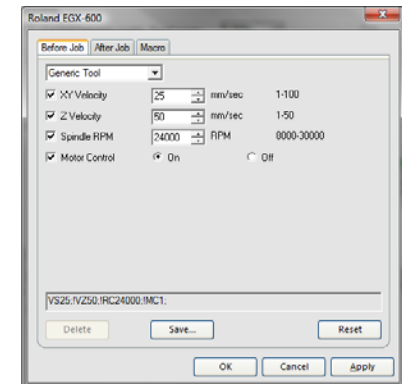
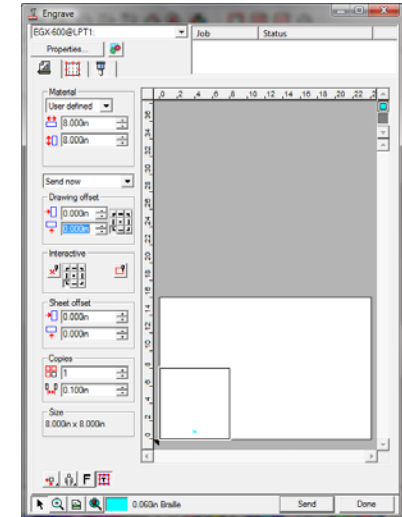



FlexiEngrave Configuration for ADA/Braille Signage.

- ❖ Brush off the excess material and weed away the tactile material to show the finished product and frame and/or mount.
- ❖ Your ADA compliant sign is now complete.



Imagine.  **Roland**®

For more information on Roland Signmaking Systems, please visit Roland DGA Corporation at www.rolanddga.com.



For more information about Raster™ Braille, please contact Accent Signage Systems at www.accent signage.com